

KLEMMSOCKEL VERSCHIEBBARE FLANSCH VERSTELLBARE VERSCHRAUBUNG

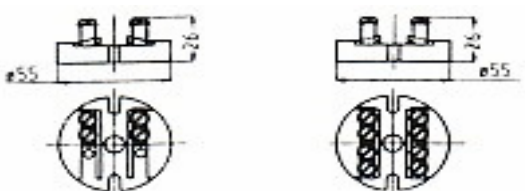
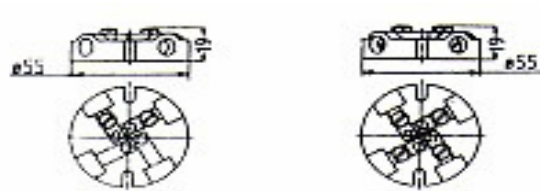
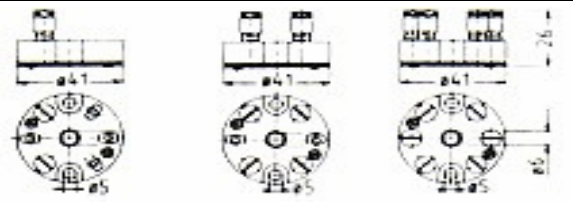
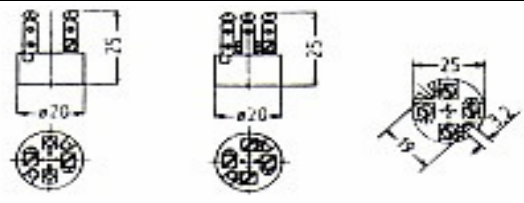

Form A, max. Draht- Ø 1,38 mm		Form A, max. Draht- Ø 3 mm	
			
SA 321	SA 341	SA 331	SA 351
321200	321400	322200	322400

Form B, max. Draht- Ø 1,38 mm			Form S, max. Draht- Ø 1 mm Form C		
					
SB 640/B2	SB 641/B4	SB 642/B6	SC 044/B2	SC 094/B4	SC 095
Ø6	323206	323406	324200	324400	C2 325201
Ø8	323208	323408			C3 325301
					C4 325401

Material	Schutzrohr Ø in mm	Abmessung en		Typ	Artikel-Nr.
		C	A		
Stahl (Anschlagflansch)	15	55	75	BC 011	521015
	22	70	90	BC 021	521022
	32	70	90	BC 031	521032
Stahl (Gegenflansch)	15	55	75	CBC 562	522015
	22	70	90	CBC 563	522022
	26	70	90	CBC 564	522026



Rohr Ø	Gewinde	Abmessungen mm		SW mm	Typ	Artikel-Nr
		L1	L2			
15 mm	1/2" G c	50	20	24	RC 216	518000
22 mm	3/4" G c	52	16	32	RC 426	518003

